

GENUINE REAR UNDER GARNISH

INSTALLATION AND USER'S INSTRUCTIONS

Thank you for purchasing a Genuine Mazda Accessory.



Before removal and installation, please thoroughly read these instructions.

For your safety, please read the contents of this booklet to properly install and use the rear under garnish.

Keep these instructions with your vehicle records for future reference.



WARNING

- There are several  **WARNING** and  **CAUTION** sections in this booklet concerning safety when installing or removing the rear under garnish. Always read and follow the instructions in order to prevent injuries, accidents, and possible damage to the vehicle.

 **WARNING:** Indicates a situation in which serious injury or death could result if the warning is ignored.

 **CAUTION:** Indicates a situation in which bodily injury or damage to the vehicle could result if the caution is ignored.

- For areas indicating the tightening torque in this instruction manual, tighten to the specified torque by using a torque wrench. For areas in which the tightening torque is indicated inside parentheses (), the tightening torque is indicated as a reference value, however tightening using a torque wrench is not necessary
- Do not modify the rear under garnish.
- Do not install the rear under garnish in any way other than described in the following instructions.
- If in doubt, please contact your Mazda dealer to install the accessory in order to prevent errors in installation.
- If you have any questions about the use of the accessory, ask your Mazda dealer for proper advice before using it.
- Mazda and its suppliers are not responsible for injuries, accidents, and damage to persons and property that arise from the failure of the dealer or installer to follow these instructions.
- To ensure safety and reliability of the work, installation, removal and disposal work must be carried out by an Authorized Mazda Dealership.
- Be careful not to lose removed parts, and be sure that they are kept free of dirt, scratches, or damage.

PART NAME: REAR UNDER GARNISH

PART NUMBER: KB7W V3 300

KB8W V3 300(VEHICLES WITH TRAILER HITCH)

VEHICLE: MAZDA CX-5

NOTE

To the dealer

- Please turn over these instructions to the customer after installation.

To the customer





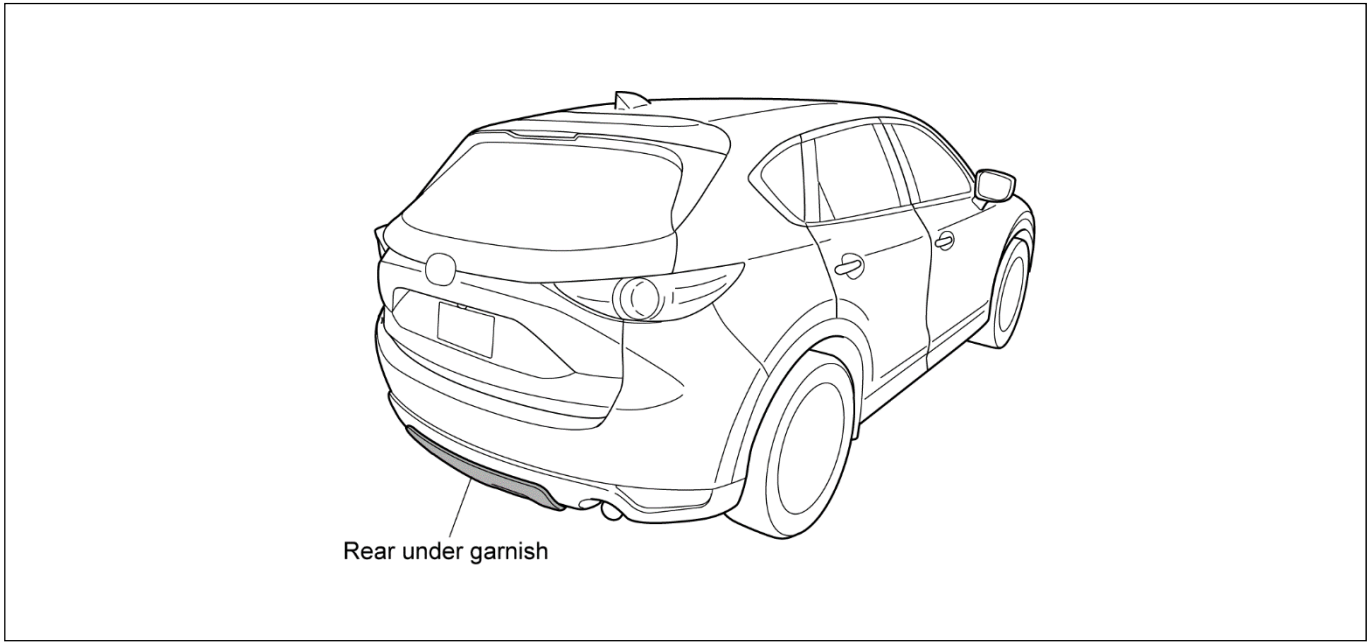

- Keep these instructions after installation. The instructions may be necessary for installing other optional parts or removal of this accessory.
- Should the vehicle or this accessory be resold, Always transfer these instructions to the next owner.

1. INSTALLATION VIEW

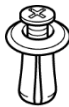

2. PARTS

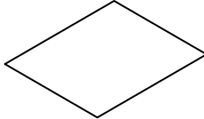
- Before installation, verify that the kit includes all the following parts and that they are free of dirt, scratches, or damage.

| Part | Part name | Qty | Part | Part name | Qty |
|--|--------------------|-----|--|---|--------|
|  | Rear under garnish | 1 |  | Fastener | 2 |
| For vehicles with trailer hitch  | | |  Thick type (2) |  Thin type (1) | Spacer |
|  | Flange nut | 2 |  | Template | 4 |
|  * Before installing, set the washers onto the tapping screws. | Tapping screw | 2 |  | Installation and user's instructions | 1 |

3. BEFORE INSTALLATION

REQUIRED TOOLS

☆ Drill (φ 3mm、φ 6mm、φ 8mm、φ 8.5mm) ☆ Torque wrench ☆ Punch ☆ Phillips screwdriver

OTHER PREPARATIONS



☆ Promoter ☆ Isopropyl alcohol

⚠ WARNING

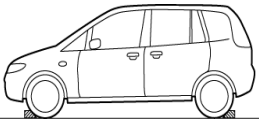
Park the vehicle on a flat, level surface, apply the parking brake and block the wheels so that the vehicle does not move during installation.

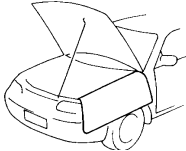
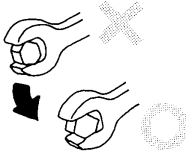
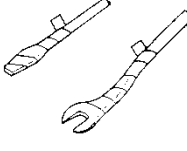
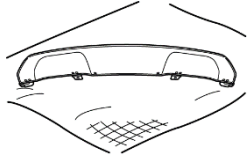
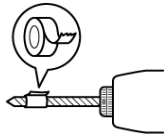
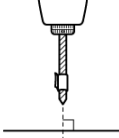

⚠ CAUTION

| | | | |
|--|---|--|--|
| <p>Be sure to cover the vehicle body with protectors or mats to prevent stains, scratches and damage when removing/installing the vehicle parts</p> | <p>Using improper tools may cause damage and/or broken parts. Use the correct tool for the installation.</p> | <p>Wrap protective tape around screwdrivers and fastener remover tools to prevent scratching the vehicle.</p> | <p>Put the removed parts and the parts in the kit on the protective sheet to prevent scratches.</p> |
|  |  |  |  |
| <p>【Drilling】 When drilling holes, be sure to wrap the drill bit with adhesive tape or similar to prevent drilling from going too deep.</p> | <p>【Drilling】 When drilling holes, hold the drill bit or hole saw so that it is perpendicular to the drilling surface so that the position of the hole being drilled does not shift.</p> | <p>【Drilling】 After drilling holes, file away any rough edges and burrs until the edges are smooth.</p> | <p>If there is any dirt, grease or other contamination on the attachment surface, they may become attached to the double-sided tape, causing a drop in the adhesive strength of the double-sided tape. You should clean the attachment surface thoroughly before attaching the tape. Use IPA (isopropyl alcohol) or similar to clean interior and exterior surfaces.</p> |
|  |  |  |  |

4. DOUBLE-SIDED TAPE ATTACHMENT

* "Attachment surface" refers to the doors and/or bumper, and "part" refers to accessory parts.

1. Avoid working in ambient temperatures of less than 15 °C.

The stickiness of the adhesive depends on the softness of the resin, and so the adhesive loses its stickiness and the adhesive strength drops at low temperatures (15 °C or less). Accordingly, avoid carrying out work in places where the ambient temperature is less than 15 °C. If working in places where the ambient temperature is less than 15 °C, you should heat the attachment surface and the part until they are warm enough.

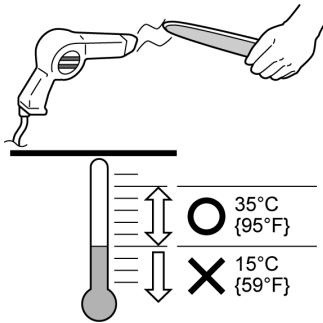

2. Attach evenly.

In order to ensure that the adhesive surface of the double-sided tape attaches correctly, it is necessary to press the adhesive surface of the tape against the attachment surface with a uniform force (50N) overall. In particular, press down sufficiently on the double-sided tape when the ends of the tape and the attachment surface are curved.

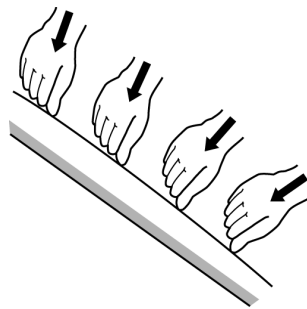

3. Clean the attachment surface.

If there is any dirt, grease or other contamination on the attachment surface, they may become attached to the double-sided tape, causing a reduction in the adhesive strength of the double-sided tape. You should clean the attachment surface before attaching the double-sided tape. As a general rule, use neutral detergent for interior surfaces, and use IPA (isopropyl alcohol) or white gas for exterior surfaces. After cleaning, fully dry the cleaned area.

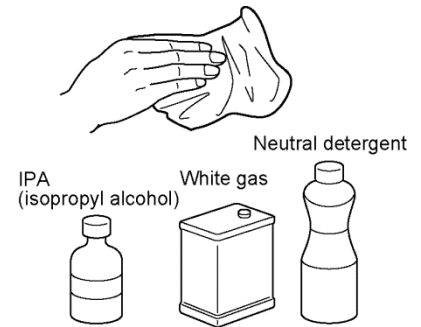

4. Avoid getting the tape dirty.

If you touch the adhesive surface while working, oil from your hands can get onto the adhesive and cause a drop in the adhesive strength of the double-sided tape. In addition, when working while wearing gloves, fibers and dirt from the gloves may become attached to the adhesive. Take care to avoid contaminating the adhesive surface of the double-sided tape.

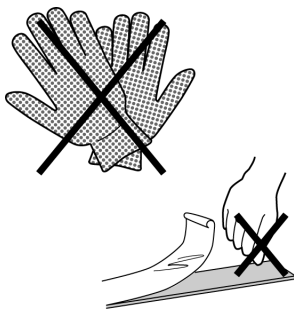

5. Handling after attaching the tape.

After the tape has been attached, the adhesive strength will not stabilize until 24 hours have passed, so do not drive or wash the vehicle or leave it exposed to rain for 24 hours. In addition, never remove and reattach the double-sided tape once the product has been installed, as this will result in a dramatic drop in adhesive strength.

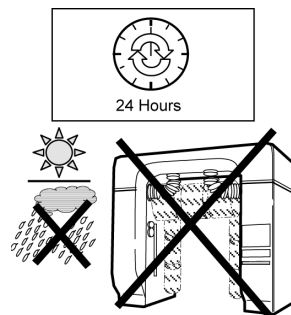

5. REAR UNDER GARNISH INSTALLATION

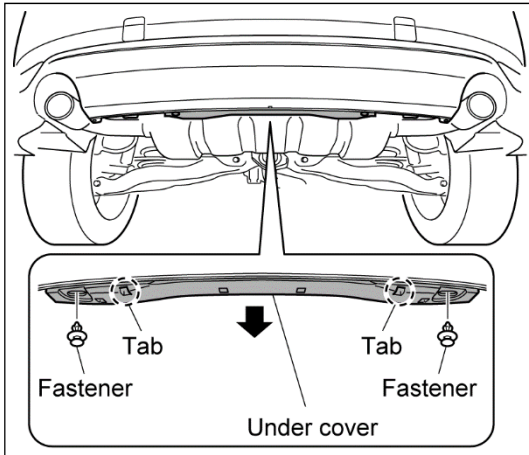

Vehicle part removal (vehicles with under cover only)

1. Remove the fasteners (2 places) from the under cover underneath the rear bumper.
2. Disengage the tabs (2 places), and then remove the under cover.

- For vehicles without trailer hitch, the under cover and fasteners which were removed will be reused.
- For vehicles with trailer hitch, the under cover and fasteners will not be reused.

Rear under garnish mounting hole drilling

1. Cut the templates. (2 for LH, 3 for RH)
2. Attach each of the templates to the rear bumper with tape as shown in the illustration below.
3. Use a punch to make marks at the centers of the $\phi 8$ mm and $\phi 8.5$ mm holes in the templates. (5 places)

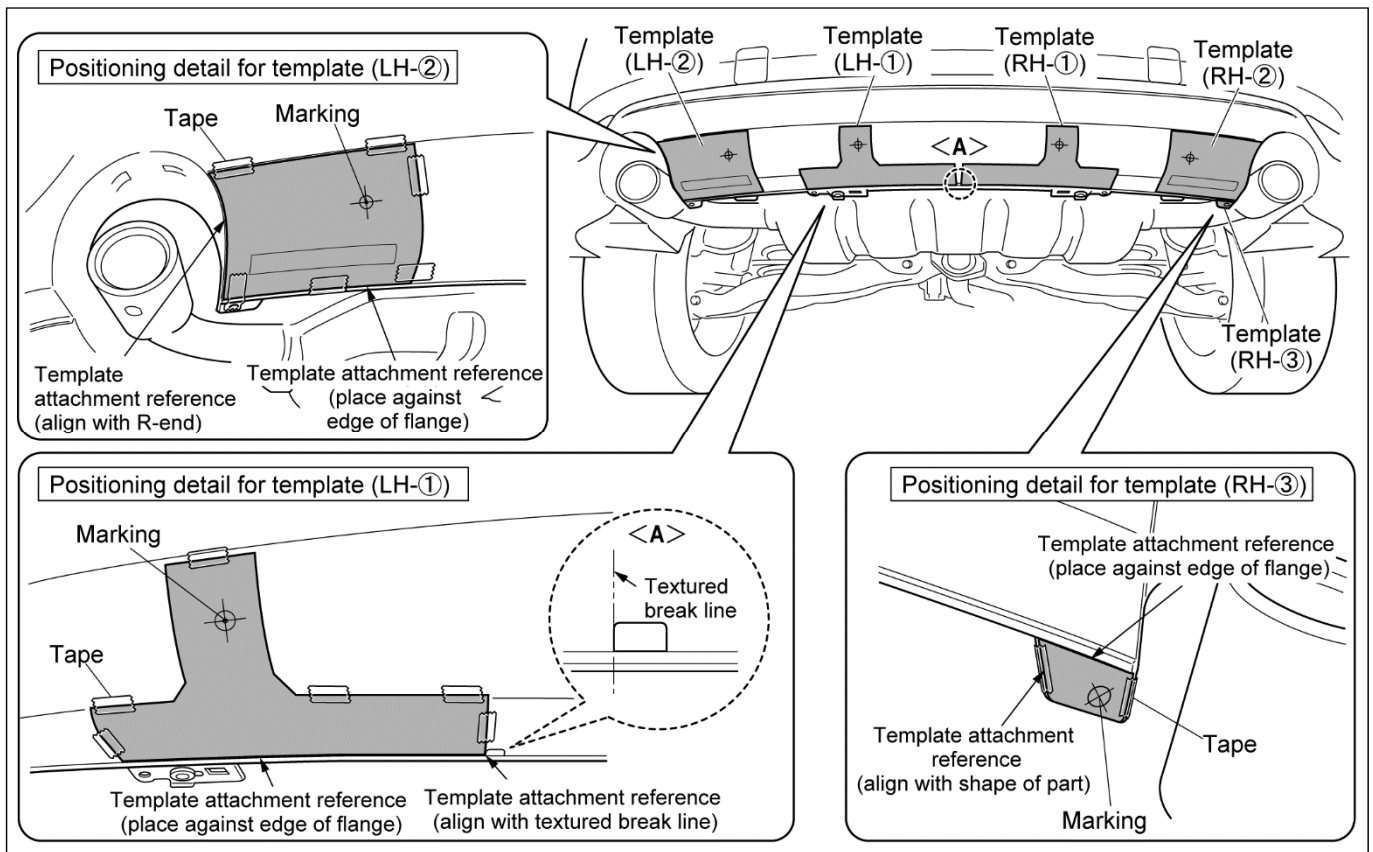

4. Remove the templates.

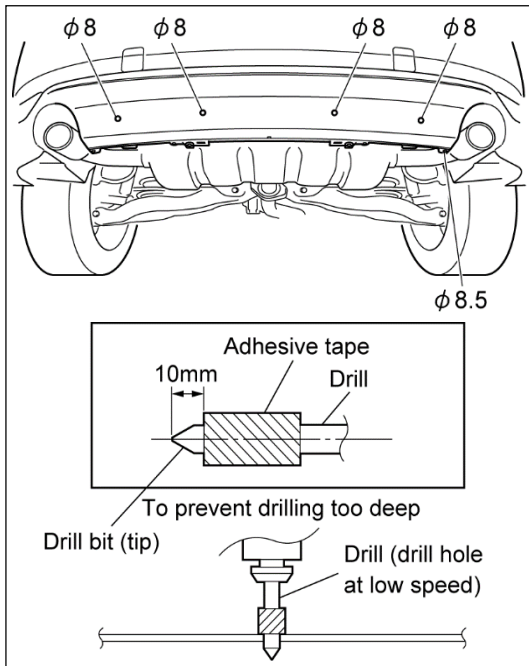

5. Use the drill to drill $\phi 6$ mm, $\phi 8$ mm and $\phi 8.5$ mm holes in stages at the locations of the marks.
 $\phi 8$ mm holes: $\phi 3$ mm \rightarrow $\phi 6$ mm \rightarrow $\phi 8$ mm (4 places)
 $\phi 8.5$ mm hole: $\phi 3$ mm \rightarrow $\phi 6$ mm \rightarrow $\phi 8.5$ mm (1 place)
6. After drilling the holes, use a file to fully remove any burrs from the undersides of the holes.

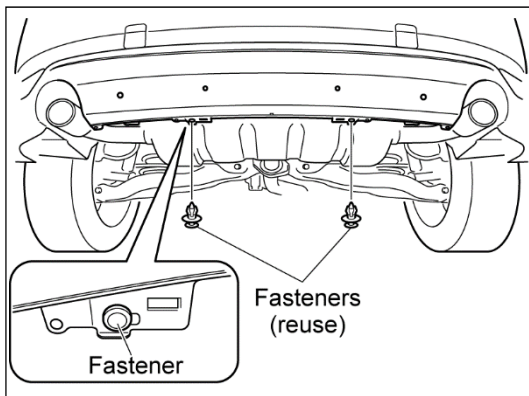
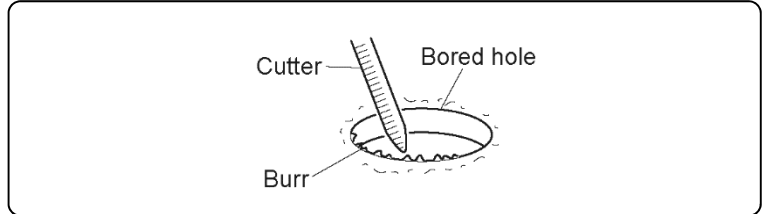

Rear under garnish installation

1. Remove the fasteners (2 places) in the positions shown in the illustration at left.

- The removed fasteners will be reused.

- For a single muffler (vehicles with exhaust pipe cover), also remove the fastener in the position shown in the illustration below. (Left side only)
-
- The removed fastener will not be reused.

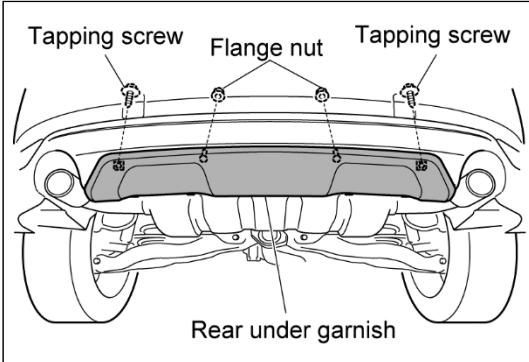

2. Place the rear under garnish against the rear bumper, and temporarily install it from underneath the rear bumper with the flange nuts (2 places) and the tapping screws with washers on them (2 places).

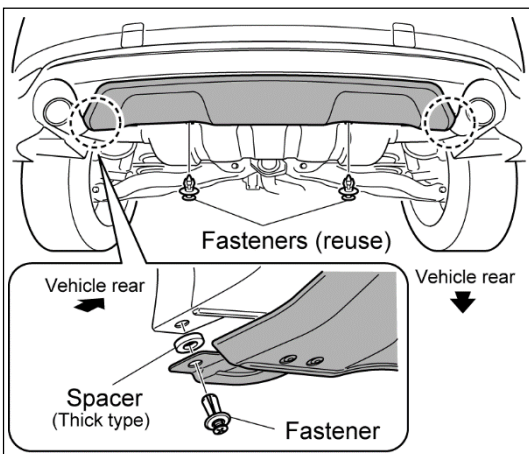

3. After inserting the fasteners (2 places: reused) inside the underside of the rear bumper and inserting the thick spacers into the gaps between both ends of the bracket and the rear bumper, temporarily tighten the fasteners (2 places).

- For vehicles with single muffler (vehicles equipped with exhaust pipe cover), the gaps between the bracket and the rear bumper, insert the thin spacer on the left side, and insert the thick spacer on the right side.
-

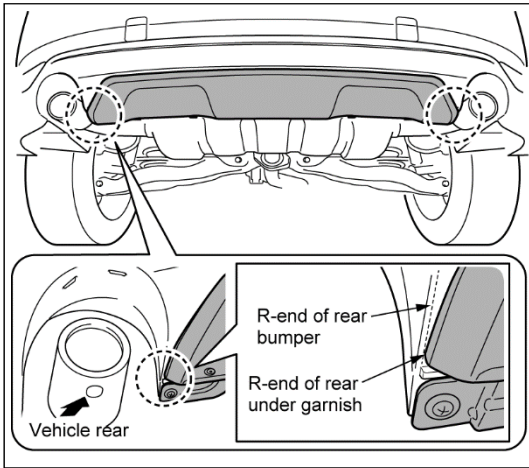

- Align the R-end position of the rear under garnish with the R-end of the rear bumper, and then adjust the position of the rear under garnish so that the gaps at left and right are uniform.

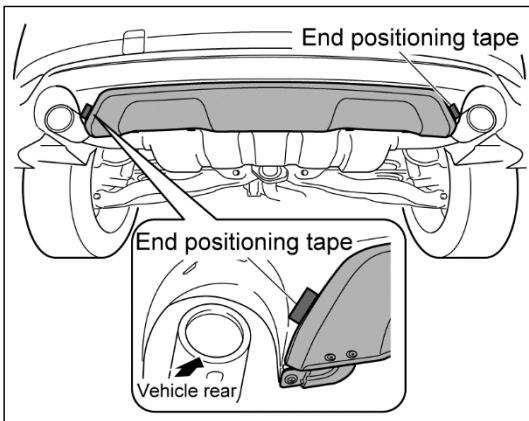

- Attach tape at the left and right ends of the rear under garnish to mark the end positions.

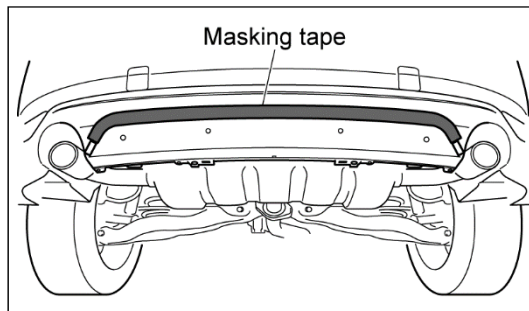

- Attach masking tape around the outside edge of the rear under garnish which has been temporarily installed within the area shown in the illustration.

- Remove the fasteners (4 places, including spacers at both ends) which were temporarily installed, the flange nuts (2 places) and the tapping screws with washers (2 places), and then remove the rear under garnish which was temporarily installed.

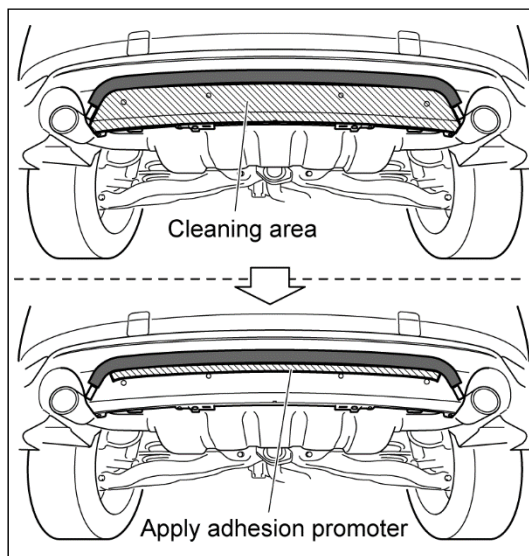

- Use IPA (isopropyl alcohol) or white gas to clean the whole area where the rear under garnish will be installed.

(Inside masking tape)

- Apply adhesion promoter (not included) to the area of the rear under garnish where the double-sided tape is to be attached.

(Inside masking tape)

- After applying the adhesion promoter, let it dry sufficiently.

- Remove all of the masking tape.

- Do not peel off the end positioning tape which was attached in step 5, as it will be used as the installation reference when installing the rear under garnish.

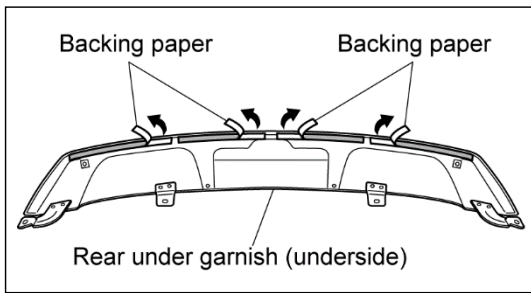

11. Peel off part of the backing paper from the pieces of double-sided tape on the rear under garnish, and fold them toward the outside.

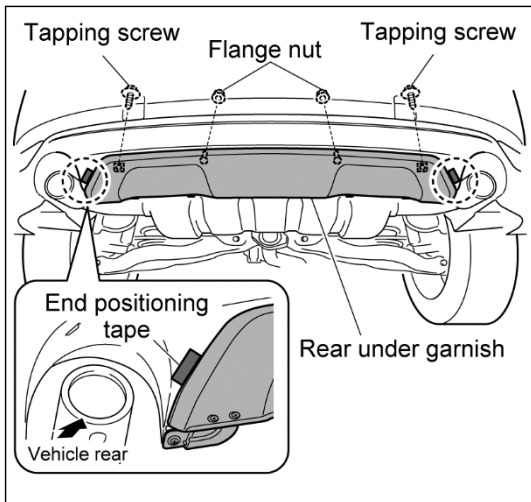

12. Place the rear under garnish against the rear bumper, and provisionally install it with the flange nuts (2 places) and the tapping screws with washers on them (2 places).

13. Adjust the position of the rear under garnish so that the left and right ends are aligned with the end positioning tape which was attached in step 5.

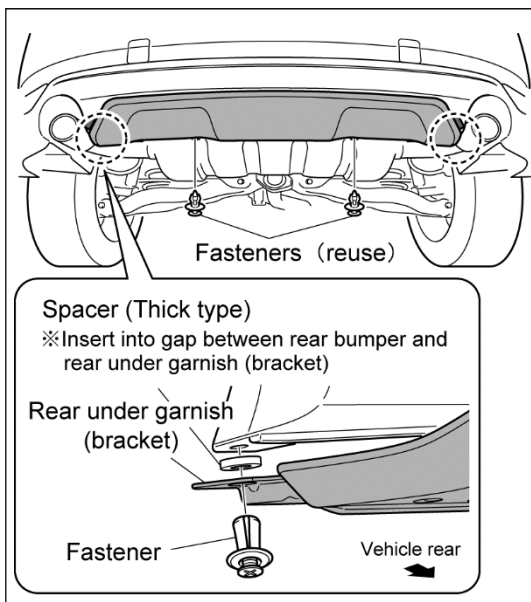

14. After inserting the fasteners (2 places: reused) of the rear under garnish and inserting the spacers (2 places: thick type) into the gaps between both ends of the bracket and the bumper, tighten the fasteners (2 places).

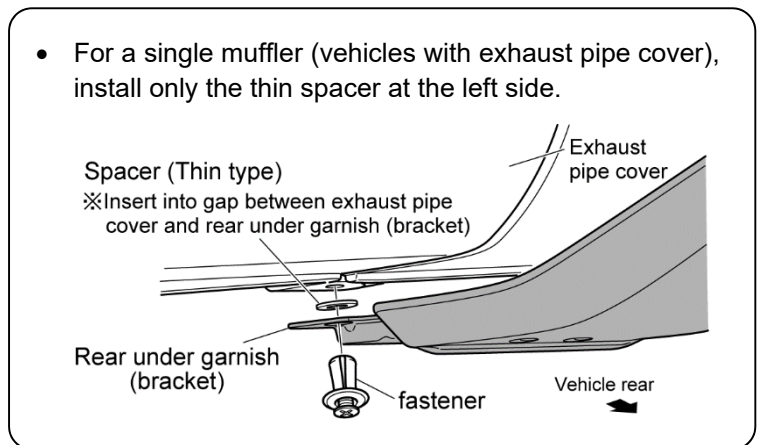

15. Check that the rear under garnish and the rear bumper are aligned, and adjust their positions so that the gaps at both left and right ends of the bumper are uniform.

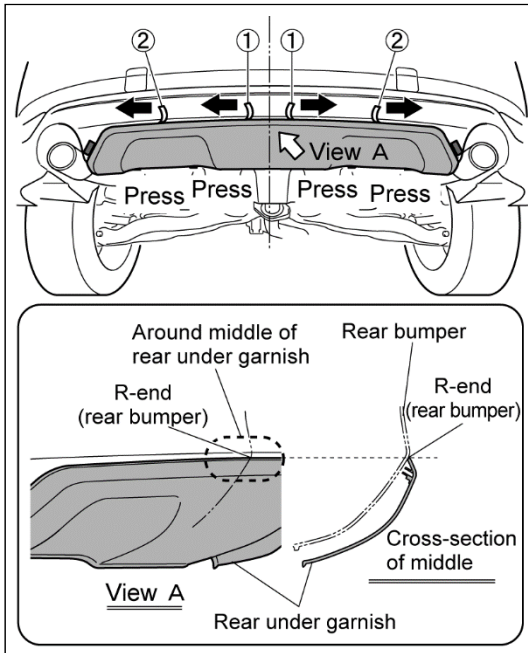

16. While lifting up the rear under garnish so that the middle area is at the position of the R-end of the rear bumper, peel off the backing paper in the direction of the arrows in the order of ① → ②, and then press down on the double-sided tape to attach it.

- Attach the double-sided tape securely to the vehicle body.
- Do not detach the tape once it has been attached. If it is detached once it has been attached, the adhesive strength will be reduced.

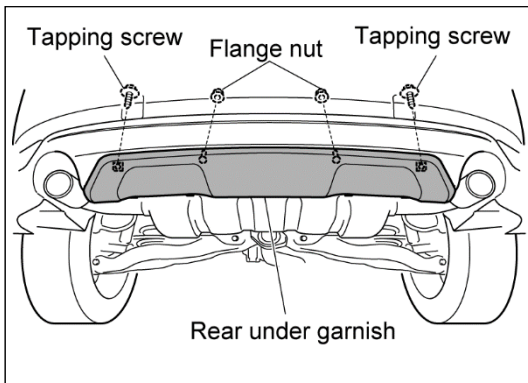

17. Remove the end positioning tape which is attached at both ends of the rear under garnish.

18. Fully tighten the flange nuts (2 places) and tapping screws (2 places) on the underside of the bumper which were provisionally installed in step 12.

Tapping screw tightening torque: (0.8—1.2 N·m)

Flange nut tightening torque: (1.2—1.5 N·m)

Vehicle part reassembly (vehicles with under cover only)

1. Reassemble the under cover by following the removal procedure in reverse.

- For vehicles with trailer hitch, it is not necessary to reassemble the under bumper.