

GENUINE INSTRUMENT PANEL DECORATION PANEL

INSTALLATION AND USER'S INSTRUCTIONS

Thank you for purchasing a Genuine Mazda Accessory.

Before removal and installation, Please thoroughly read these instructions.

For your safety, please read the contents of this booklet to properly install and use the instrument panel decoration panel.

Keep these instructions with your vehicle records for future reference.



- There are several **⚠ WARNING** and **⚠ CAUTION** sections in this booklet concerning safety when installing or removing the instrument panel decoration panel. Always read and follow the instructions in order to prevent injuries, accidents, and possible damage to the vehicle.

⚠ WARNING: Indicates a situation in which serious injury or death could result if the warning is ignored.

⚠ CAUTION: Indicates a situation in which bodily injury or damage to the vehicle could result if the caution is ignored.

- For areas indicating the tightening torque in this instruction manual, tighten to the specified torque by using a torque wrench. For areas in which the tightening torque is indicated inside parentheses (), the tightening torque is indicated as a reference value, however tightening using a torque wrench is not necessary
- Do not modify the instrument panel decoration panel.
- Do not install the instrument panel decoration panel in any way other than described in the following instructions.
- If in doubt, please contact your Mazda dealer to install the accessory in order to prevent errors in installation.
- If you have any questions about the use of the accessory, ask your Mazda dealer for proper advice before using it.
- Mazda and its suppliers are not responsible for injuries, accidents, and damage to persons and property that arise from the failure of the dealer or installer to follow these instructions.
- To ensure safety and reliability of the work, installation, removal and disposal work must be carried out by an Authorized Mazda Dealership.
- Be careful not to lose removed parts, and be sure that they are kept free of dirt, scratches, or damage.

PART NAME: INSTRUMENT PANEL DECORATION PANEL

PART NUMBER: NA1J V1 170

NA1P V1 170

NA1V V1 170

VEHICLE: MAZDA MX-5

NOTE

To the dealer

- Please turn over these instructions to the customer after installation.

To the customer

- Keep these instructions after installation. The instructions may be necessary for installing other optional parts or removal of this accessory.
- Should the vehicle or this accessory be resold, Always transfer these instructions to the next owner.

- If installing the Genuine Mazda foot lamp & illumination at the same time, install the instrument panel decoration panel first.

1. INSTALLATION VIEW

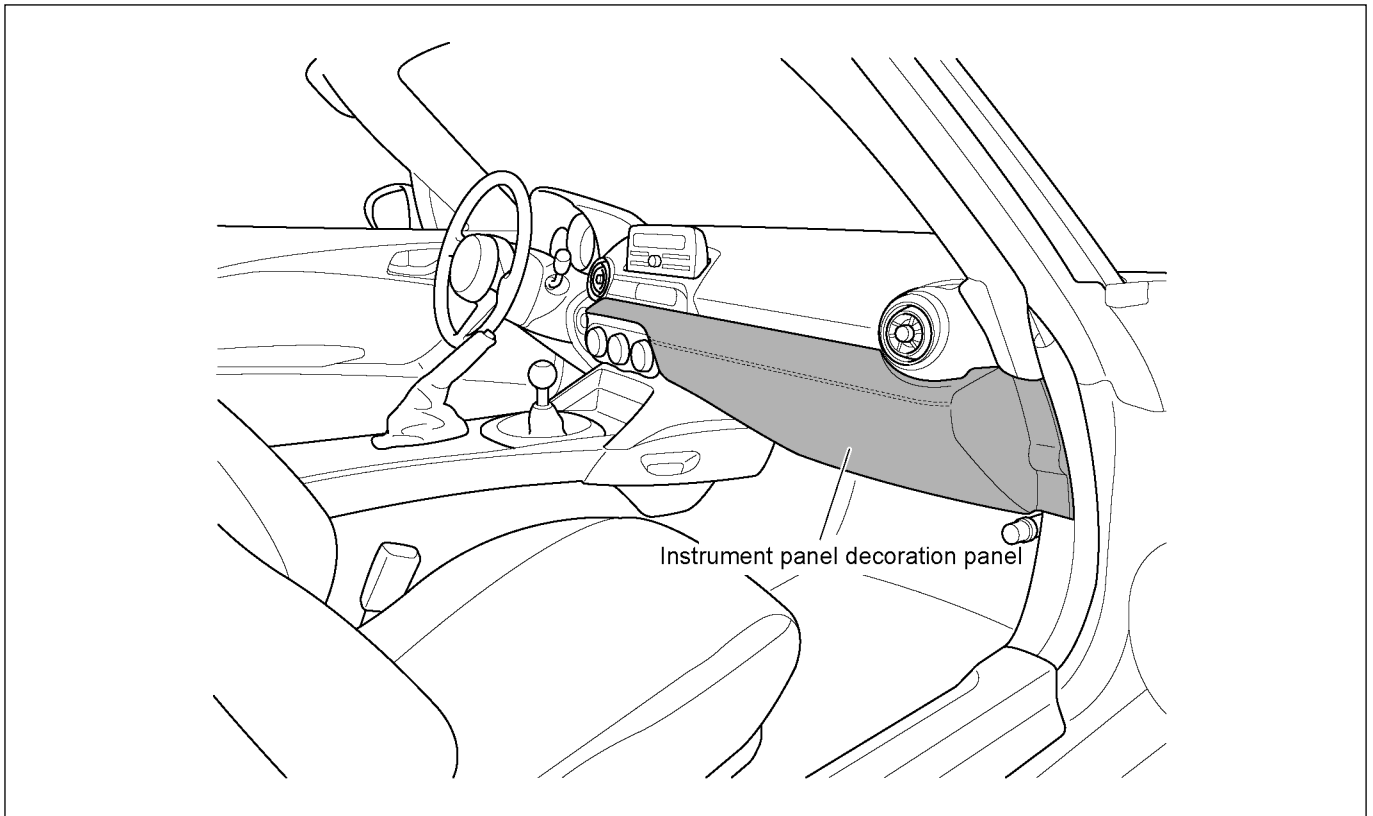

2. PARTS

- Before installation, verify that the kit includes all the following parts and that they are free of dirt, scratches, or damage.

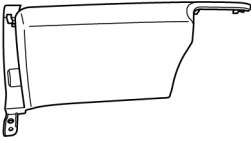
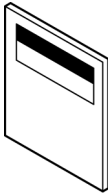
Part	Part name	Qty	Part	Part name	Qty
	Instrument panel decoration panel	1		Installation inspection sheet	1

3. BEFORE INSTALLATION

■ REQUIRED TOOLS





☆Fastener remover

☆Ratchet wrench (10 mm)

☆Torque wrench

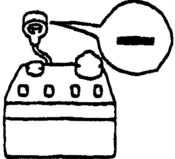
☆Spanner (10 mm)

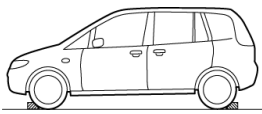
⚠ WARNING

<p>When the negative battery cable is connected during operation, it may cause electric shock or other injuries. Disconnect the negative battery cable before removal/installation.</p>	<p>Do not pull wiring harnesses with excessive force. Doing so can cause breakage or a short circuit-related accident, as well as an electrical short or fire.</p>	<p>Park the vehicle on a flat, level surface, apply the parking brake and block the wheels so that the vehicle does not move during installation.</p>	<p>When connecting/disconnecting connectors, grasp the connectors, not the wires. Otherwise a short, an accident from poor contact or fire may occur.</p>
			

⚠ CAUTION

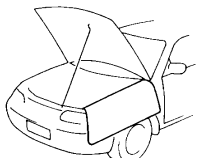
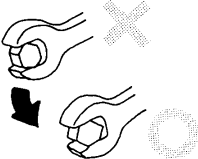
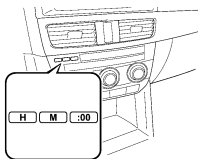
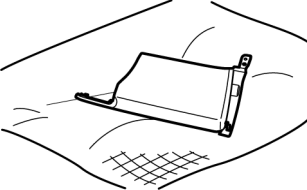
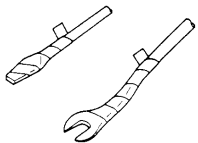
<p>Be sure to cover the vehicle body with protectors or mats to prevent stains, scratches and damage when removing/installing the vehicle parts</p>	<p>Using improper tools may cause damage and or broken parts. Use the correct tool for the installation.</p>	<p>When the negative battery cable is disconnected from the battery, the clock, radio, trip meters and other memories will be erased. Before performing work, record the content of the memory.</p>	<p>Put the removed parts and the parts in the kit on the protective sheet to prevent scratches.</p>
			
<p>Wrap protective tape around screwdrivers and fastener remover tools to prevent scratching the vehicle.</p>			
			

Advice

Refer to the Workshop Manual for removal and installation of vehicle parts. Not following the procedures for removal/installation in the Workshop Manual could result in an accident or vehicle malfunction.



4. VEHICLE PART REMOVAL

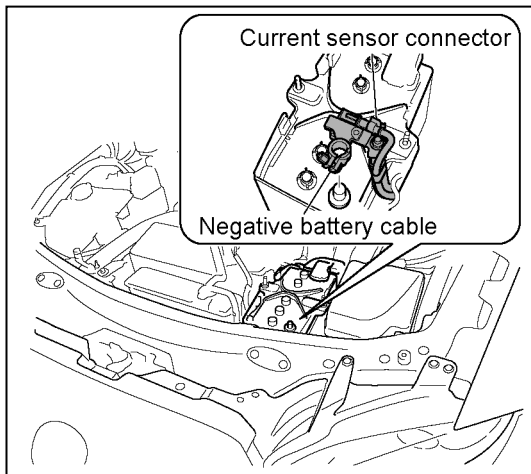

Negative battery cable disconnection

1. Move the selector lever to the "P" position. (A/T vehicles only)

⚠ WARNING

- Take care while working to avoid damage to components, electric shocks or injury as a result of electrical short-circuits.
- Check that all vehicle functions are restored, while referring to "Necessary tasks to carry out after disconnecting/reconnecting the battery (-) cable" in the vehicle workshop manual and also to the owner's manual.

2. Disconnect the negative battery cable, and then wrap the negative terminal of the battery with tape or similar to insulate it.

Tightening torque: (4.0-6.0 N·m)

3. Disconnect the current sensor connector.

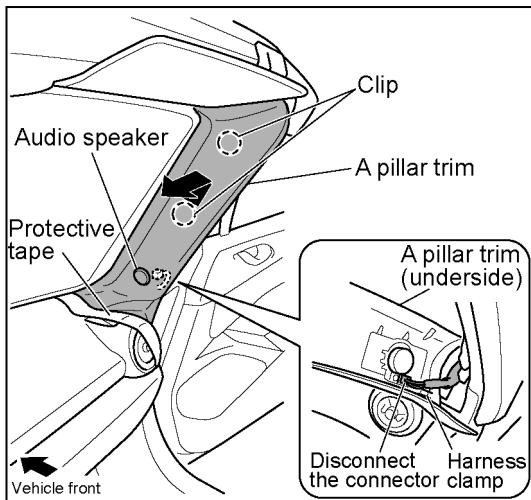

A pillar trim removal (passenger's side)

- Attach protective tape to prevent any vehicle parts from becoming damaged.

1. Disengage the clips (2 places).
2. Remove the harness clamp, remove the audio speaker, and then disconnect the connector.
3. Remove the A pillar trim in the direction of the arrow.

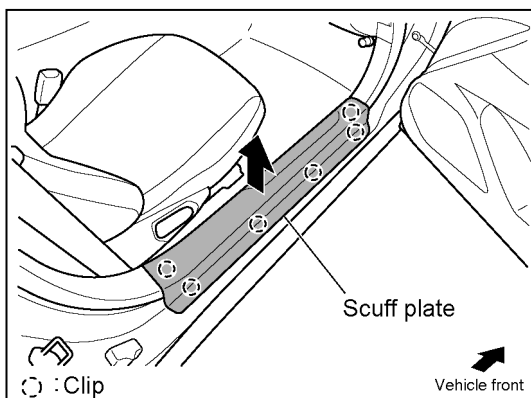

Scuff plate removal (passenger's side)

1. Disengage the clips (6 places), and then remove the scuff plate.

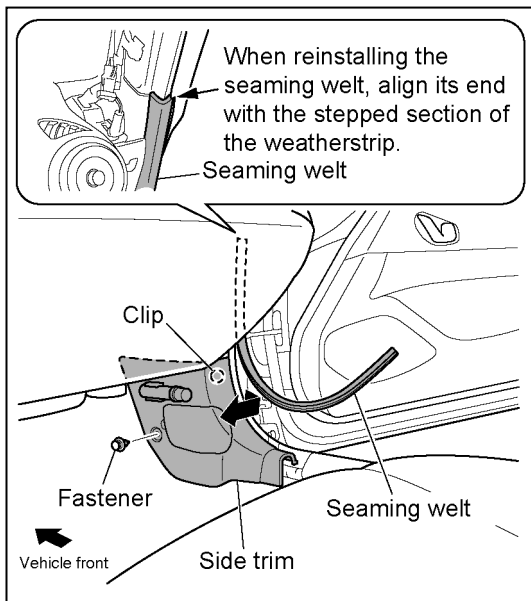

Side trim removal (passenger's side)

1. Remove the seaming welt.
2. Remove the fastener (1 place).
3. Disengage the clip (1 place), and then remove the side trim in the direction of the arrow.

5. INSTRUMENT PANEL DECORATION PANEL INSTALLATION

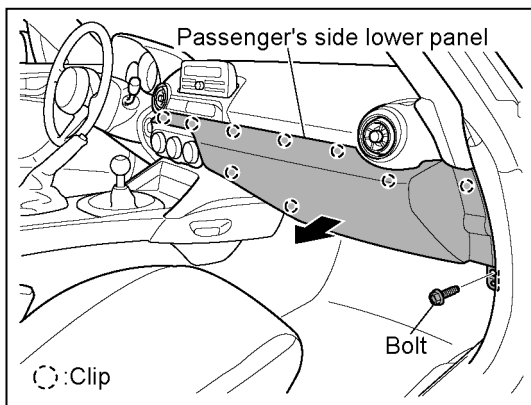

1. Remove the bolt (1 place) from the passenger's side lower panel.

Bolt tightening torque: (2.0-6.0 N·m)

2. Disengage the clips (9 places), and then remove the passenger's side lower panel in the direction of the arrow.

- The removed passenger's side lower panel (existing part) will not be reused.

3. Install the instrument panel decoration panel by following the removal procedure in reverse.

6. REASSEMBLY AND INSPECTION

1. Install the other vehicle parts by following the procedure in "Vehicle Part Removal" in reverse.
(Side trim, seaming welt, scuff plate, A pillar trim, negative battery cable)
2. Check that all vehicle functions are restored, while referring to "Necessary tasks to carry out after disconnecting/reconnecting the battery (-) cable" in the vehicle workshop manual.
3. Carry out a reassembly inspection for the vehicle parts and check that all items are installed.

7. CAUTIONS ON HANDLING

Be sure to observe the following when handling (cleaning) Alcantara®.

Daily cleaning

To keep Alcantara® in good condition, clean it periodically (about once a month).

- Wipe all over with a cloth which has been moistened with lukewarm water and then wrung dry, and then once it has dried, smooth it over using a soft brush.

If dirty from liquids

- If liquids have spilled onto the surface, dab the spilled area with a material such as tissue paper to soak up the liquid.
- If the surface is stained with mud or similar that has dried and solidified, use a soft brush or similar to gently brush the stained area so as to remove the dirt, and then use a vacuum cleaner to remove the dirt particles.
- If the dirt is difficult to clean off, use a cloth which has been moistened with lukewarm water and then wrung dry to gently wipe the dirty area starting from the outside and working inward, and then use a soft brush or similar to smooth the surface and let it dry.

If dirty from oil or grease

- Use a dry cloth or tissue paper to clean off as much of the oil or grease as possible without spreading it further.
- Use a cloth which has been moistened with lukewarm water or pure ethyl alcohol (from liquors) and then wrung dry to gently dab the dirty area starting from the outside and working inward, and then dry the area by dabbing it with a dry cloth.
- Smooth over the area using a soft brush.