

GENUINE SPLASH GUARD (FRONT)

INSTALLATION AND USER'S INSTRUCTIONS



Thank you for purchasing a Genuine Mazda Accessory.

Before removal and installation, Please thoroughly read these instructions.

For your safety, please read the contents of this booklet to properly install and use the splash guard (front).

Keep these instructions with your vehicle records for future reference.

WARNING

- There are several  **WARNING** and  **CAUTION** sections in this booklet concerning safety when installing or removing the splash guard (front). Always read and follow the instructions in order to prevent injuries, accidents, and possible damage to the vehicle.

 **WARNING** : Indicates a situation in which serious injury or death could result if the warning is ignored.

 **CAUTION** : Indicates a situation in which bodily injury or damage to the vehicle could result if the caution is ignored.

- For areas indicating the tightening torque in this instruction manual, tighten to the specified torque by using a torque wrench. For areas in which the tightening torque is indicated inside parentheses (), the tightening torque is indicated as a reference value, however tightening using a torque wrench is not necessary.
- Do not modify the splash guard (front).
- Do not install the splash guard (front) in any way other than described in the following instructions.
- If in doubt, please contact your Mazda dealer to install the accessory in order to prevent errors in installation.
- If you have any questions about the use of the accessory, ask your Mazda dealer for proper advice before using it.
- Mazda and its suppliers are not responsible for injuries, accidents, and damage to persons and property that arise from the failure of the dealer or installer to follow these instructions.
- To ensure safety and reliability of the work, installation, removal and disposal work must be carried out by an Authorized Mazda Dealership.
- Be careful not to lose removed parts, and be sure that they are kept free of dirt, scratches, or damage.

PART NAME: SPLASH GUARD (FRONT)

PART NUMBER: VA45 V3 450

VEHICLE: MAZDA CX-50

NOTE

To the dealer

- Please turn over these instructions to the customer after installation.

To the customer

- Keep these instructions after installation. The instructions may be necessary for installing other optional parts or removal of this accessory.
- Should the vehicle or this accessory be resold, Always transfer these instructions to the next owner.



1. INSTALLATION VIEW

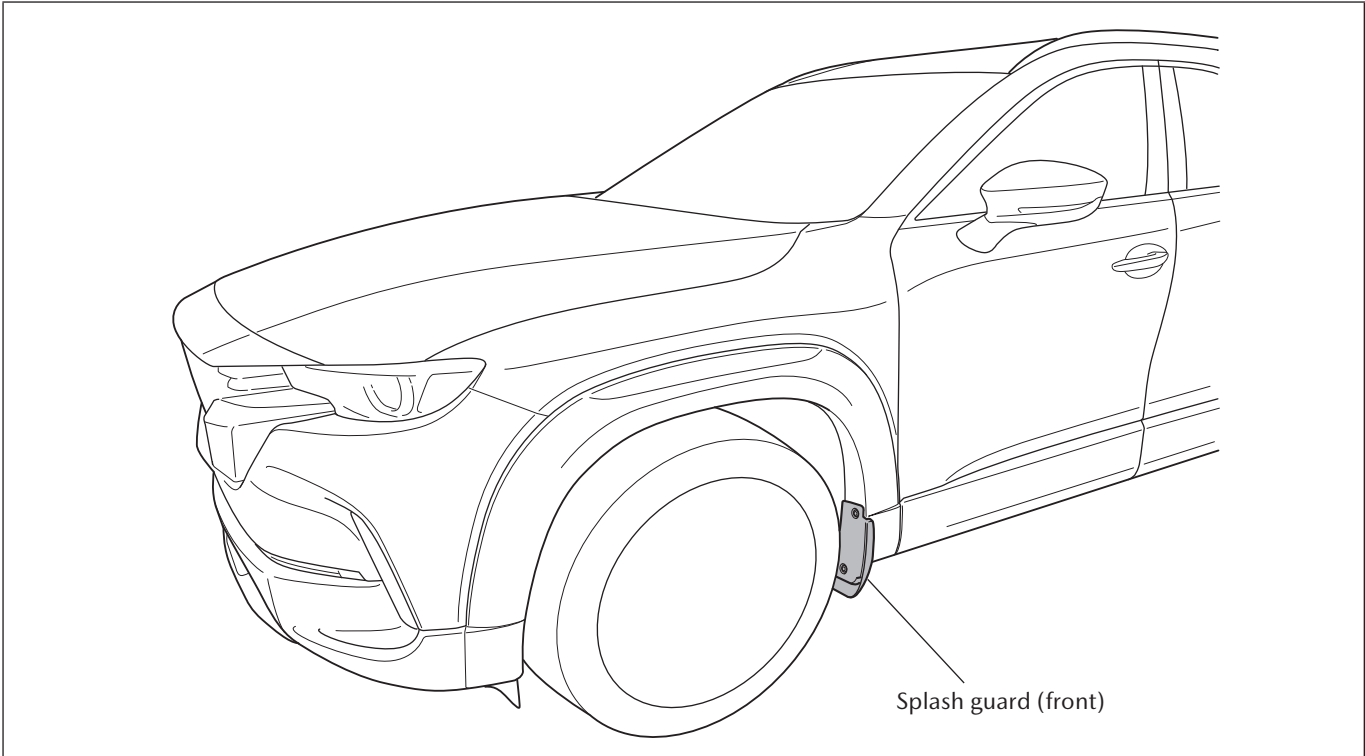

2. PARTS

- Before installation, verify that the kit includes all the following parts and that they are free of dirt, scratches, or damage.

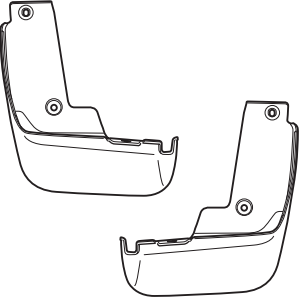
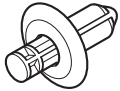
Part	Part name	Qty	Part	Part name	Qty
	Splash guard (front) (RH/LH)	Each 1		Fastener	4

3. BEFORE INSTALLATION

REQUIRED TOOLS (Make sure they are at hand before starting work)

- ☆ Fastener remover
- ☆ Drill (φ 3、φ 6、φ 9)
- ☆ Round file

Other items to prepare

- ☆ IPA (isopropyl alcohol) or white gasoline

! WARNING

Park the vehicle on a flat, level surface, apply the parking brake firmly and block the wheels so that the vehicle does not move during installation. If this is not observed, the vehicle may move and injury may result.

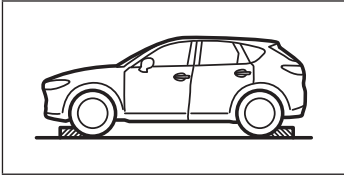

! CAUTION

<p>Be sure to cover the vehicle body with protectors or mats when removing/installing parts. Otherwise, the vehicle may be scratched or become dirty.</p>	<p>Using improper tools may cause damage and or broken parts. Use the correct tool for the installation.</p>	<p>Wrap protective tape around screwdrivers and fastener remover tools to prevent scratching the vehicle.</p>	<p>Put the removed parts and the parts in the kit on the protective sheet to prevent scratches.</p>
<p>【Drilling】 When drilling holes, be sure to wrap the drill bit with gum tape or similar to prevent drilling from going too deep.</p>	<p>【Drilling】 When drilling holes, hold the drill bit or hole saw so that it is perpendicular to the drilling surface so that the position of the hole being drilled does not shift.</p>	<p>【Drilling】 After drilling holes, file away any rough edges and burrs until the edges are smooth.</p>	

Advice

Refer to the Workshop Manual for removal and installation of applicable vehicle parts.



4. DOUBLE-SIDED TAPE ATTACHMENT

*"Attachment surface" refers to the over fender, and "part" refers to supplementary parts.

1. Avoid working in ambient temperatures of less than 15 °C.

The stickiness of the adhesive depends on the softness of the resin, and so the adhesive loses its stickiness and the adhesive strength drops at low temperatures (15 °C or less). Accordingly, avoid carrying out work in places where the ambient temperature is less than 15 °C. If working in places where the ambient temperature is less than 15 °C, you should heat the attachment surface and the part until they are warm enough.

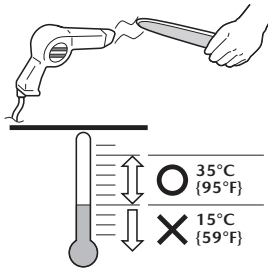

2. Attach evenly.

In order to ensure that the adhesive surface of the double-sided tape attaches correctly, it is necessary to press the adhesive surface of the tape against the attachment surface with a uniform force (50N) overall. In particular, press down sufficiently on the double-sided tape when the ends of the tape and the attachment surface are curved.

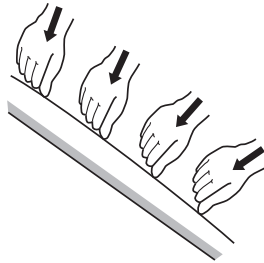

3. Clean the attachment surface.

If there is any dirt, grease or other contamination on the attachment surface, they may become attached to the double-sided tape, causing a drop in the adhesive strength of the double-sided tape.

You should clean the attachment surface before attaching the double-sided tape.

As a general rule, use mild detergent for interior surfaces, and use IPA (isopropyl alcohol) or white gas for exterior surfaces. After cleaning, let the area dry sufficiently.

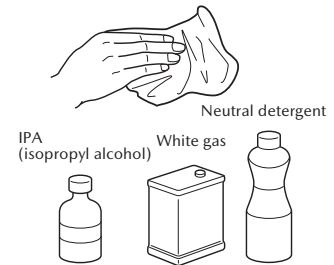

4. Avoid getting the tape dirty.

If you touch the adhesive surface while working, oil from your hands can get onto the adhesive and cause a drop in the adhesive strength of the double-sided tape.

In addition, when working while wearing gloves, fibers and dirt from the gloves may become attached to the adhesive.

Take care to avoid contaminating the adhesive surface of the double-sided tape.

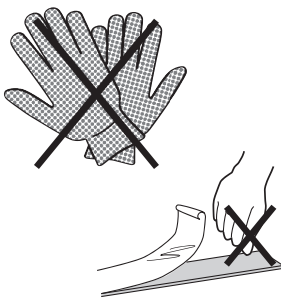

5. Handling after attaching the tape.

After the tape has been attached, the adhesive strength will not stabilize until 24 hours have passed, so do not drive or wash the vehicle or leave it exposed to rain for 24 hours.

In addition, never remove and reattach the double-sided tape once the product has been installed, as this will result in a dramatic drop in adhesive strength.

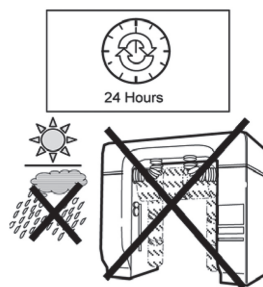

5. SPLASH GUARD (FRONT) INSTALLATION

- The illustrations showing the work procedure are for the left side of the vehicle; the same steps should be carried out for the right side as well.

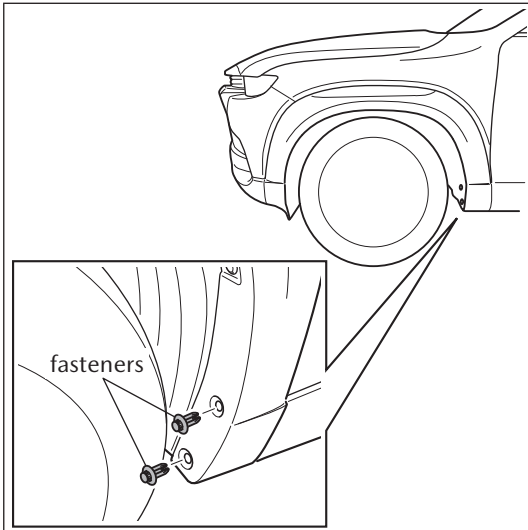

1. Remove the mudguard fasteners (2 places).

- Only one of the two fasteners which were removed will be reused.

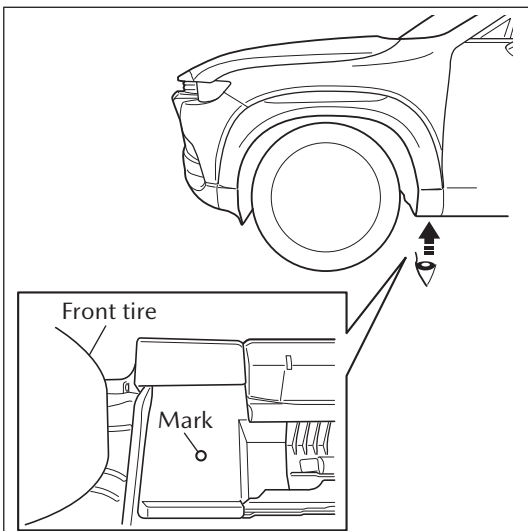

2. Check the mark for the mounting hole at the bottom of the over fender.

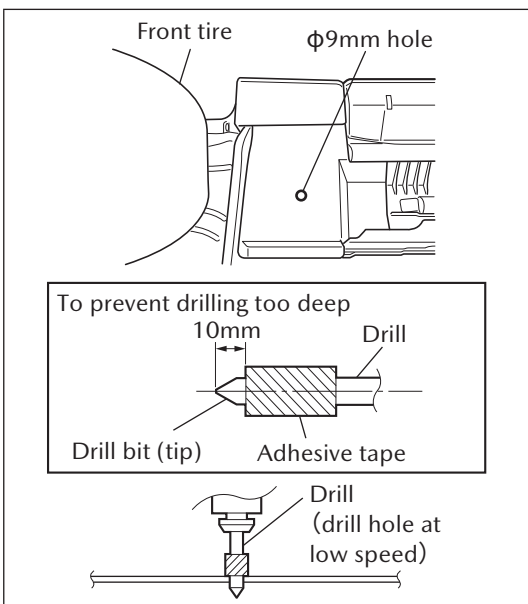

3. Use the drill to drill a $\phi 9$ mm hole in stages in the center of the mounting hole mark.

$\phi 9$ mm hole : $\phi 3$ mm \rightarrow $\phi 6$ mm \rightarrow $\phi 9$ mm

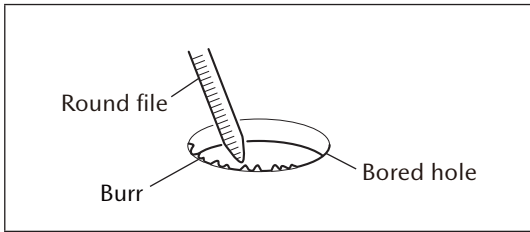

4. After drilling the hole, use a file to fully remove any burrs from the hole.

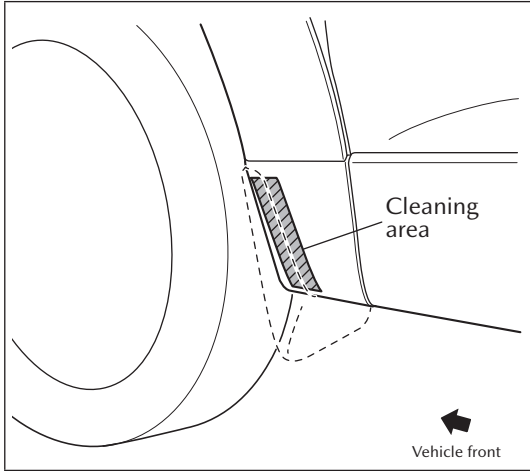

5. Use IPA (isopropyl alcohol) or white gasoline to clean the part of the vehicle (shaded area) where the double-sided adhesive tape of the splash guard (front) is to be attached.

- After cleaning, let the area dry completely.

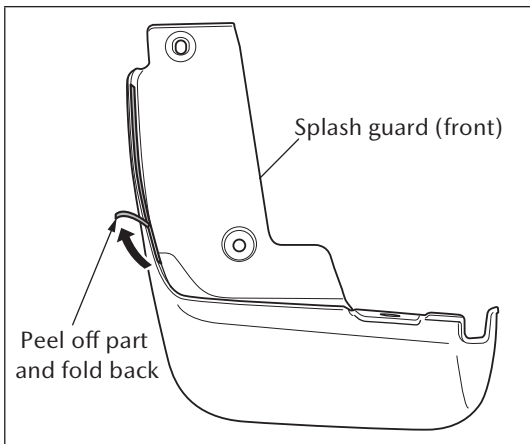

6. Peel off part of the backing paper from the double-sided adhesive tape on the splash guard (front) and fold it back.

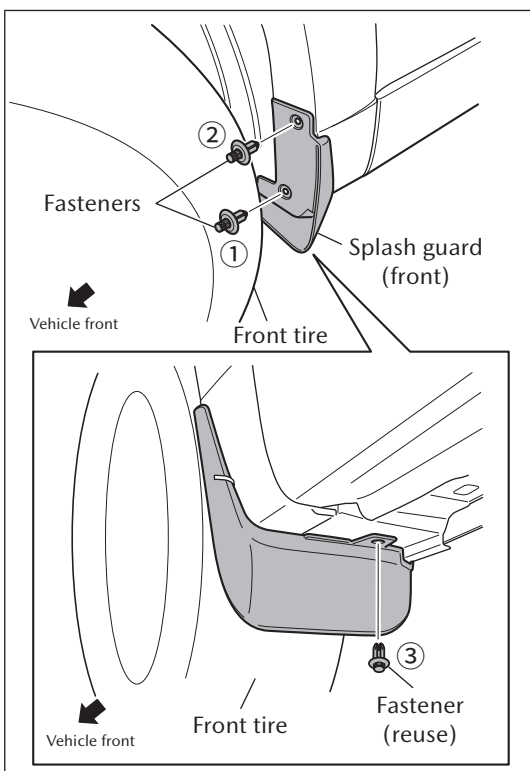

7. Set the splash guard (front) against the vehicle.

8. Install the fasteners in the order of ①, ② and ③.

- If the fasteners are stiff and difficult to install, use a rigid object such as a tool to push them in. (Refer to the diagram below.)
-

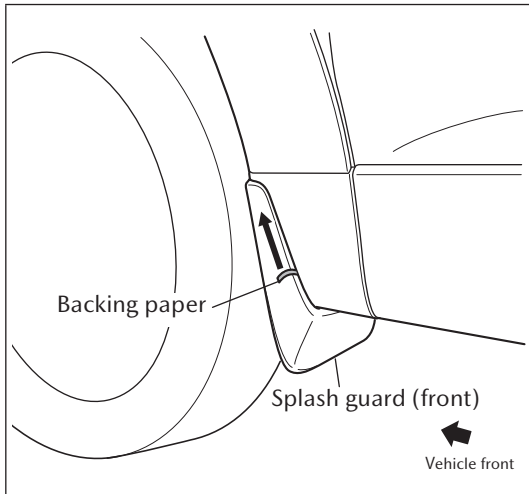

9. Peel off the backing paper from the double-sided adhesive tape in the direction of the arrow.

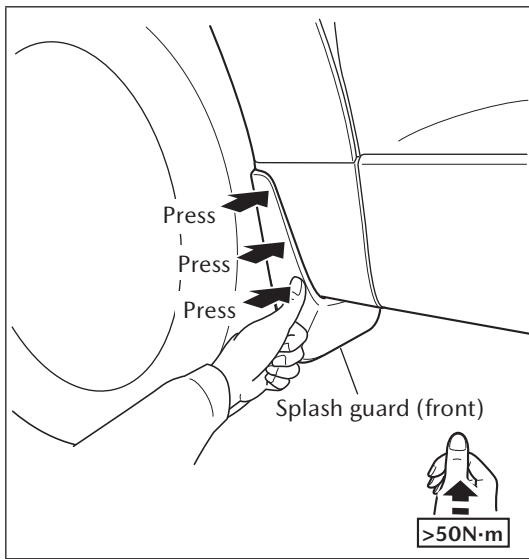

10. Press the splash guard (front) firmly against the vehicle as shown in the diagram at left to attach it so that there are no gaps between the contact surfaces.

- When attaching, press with enough force (50 N or more) so that the vehicle rocks slightly.
- Do not detach the tape once it has been attached. If it is detached once it has been attached, the adhesive strength will drop.

6. CHECKING AFTER INSTALLATION

1. Check that there are no gaps between the over fender and splash guards (front) contact surfaces.
2. Check that the fasteners are securely installed.

- With fasteners installed

Pin is pushed in and fastener is secure. Pin is not pushed in.

- Removing the fasteners

Use a screwdriver or similar tool to push in the pin and remove the fastener while being careful not to cause any damage.

7. TO THE CUSTOMER

Be sure to observe the following when handling (cleaning) the splash guards (front).

- If gasoline, oil, engine coolant, or battery fluid adheres to the hard plastic parts, it will cause discoloration, stains, or damage. Wipe off immediately with a soft cloth.
- Depending on the type of high pressure car washer used, the water for washing may be high temperature and/or under high pressure. Be careful when using pressurized water from a car washer nozzle. If the nozzle is too close or water pressure is applied for long periods, it may cause deformation or damage to the hard plastic parts.
- Do not use electric or air tools to apply wax or compound (polishing powder). Otherwise, friction heat will be generated causing deformation or damage to the hard plastic parts.
- If the vehicle height is lowered due to the vehicle being at the maximum passenger or cargo capacity described in the vehicle inspection certificate, decrease the vehicle speed when parking on a road shoulder or entering/leaving a road shoulder or bump. The splash guards (front) may get in the way and become damaged.